

SIP CONTEMPORARY SERIES

CTM-S2411-X
SIP Contemporary Cordless 1-line Hotel Phone

CTM-C4401-X
SIP Contemporary Cordless 1-line Accessory Handset

C4011-X-USB
Cordless charging stand

vtech[®]

User's Guide

IMPORTANT SAFETY INSTRUCTIONS

The applied nameplate is located at the bottom or rear of the product.

When using your telephone equipment, basic safety precautions should always be followed to reduce the risk of fire, electric shock and injury, including the following:

1. This product should be installed by a qualified technician.
2. This product should only be connected to the host equipment and never directly to the network such as Public Switch Telephone Network (PSTN) or Plain Old Telephone Services (POTS).
3. Read and understand all instructions.
4. Follow all warnings and instructions marked on the product.
5. Unplug this product from the wall outlet before cleaning. Do not use liquid or aerosol cleaners. Use a damp cloth for cleaning.
6. Do not use this product near water such as near a bath tub, wash bowl, kitchen sink, laundry tub or swimming pool, or in a wet basement or shower.
7. Do not place this product on an unstable table, shelf, stand or other unstable surfaces.
8. Slots and openings in the back or bottom of the telephone base and handset are provided for ventilation. To protect them from overheating, these openings must not be blocked by placing the product on a soft surface such as a bed, sofa or rug. This product should never be placed near or over a radiator or heat register. This product should not be placed in any area where proper ventilation is not provided.
9. This product should be operated only from the type of power source indicated on the marking label. If you are not sure of the type of power supply on the premises, consult your dealer or local power company.
10. Do not allow anything to rest on the power cord. Do not install this product where the cord may be walked on.
11. Never push objects of any kind into this product through the slots in the telephone base or handset because they may touch dangerous voltage points or create a short circuit. Never spill liquid of any kind on the product.
12. To reduce the risk of electric shock, do not disassemble this product, but take it to an authorised service facility. Opening or removing parts of the telephone base or handset other than specified access doors may expose you to dangerous voltages or other risks. Incorrect reassembling can cause electric shock when the product is subsequently used.
13. Do not overload wall outlets and extension cords.
14. Unplug this product from the wall outlet and refer servicing to an authorised service facility under the following conditions:
 - When the power supply cord or plug is damaged or frayed.
 - If liquid has been spilled onto the product.
 - If the product has been exposed to rain or water.
 - If the product does not operate normally by following the operating instructions. Adjust only those controls that are covered by the operation instructions. Improper adjustment of other controls may result in damage and often requires extensive work by an authorised technician to restore the product to normal operation.
 - If the product has been dropped and the telephone base and/or handset has been damaged.
 - If the product exhibits a distinct change in performance.

15. Avoid using a telephone (other than cordless) during an electrical storm. There is a remote risk of electric shock from lightning.
16. Do not use the telephone to report a gas leak in the vicinity of the leak. Under certain circumstances, a spark may be created when the adapter is plugged into the power outlet, or when the handset is replaced in its cradle. This is a common event associated with the closing of any electrical circuit. The user should not plug the phone into a power outlet, and should not put a charged handset into the cradle, if the phone is located in an environment containing concentrations of flammable or flame-supporting gases, unless there is adequate ventilation. A spark in such an environment could create a fire or explosion. Such environments might include: medical use of oxygen without adequate ventilation; industrial gases (cleaning solvents; petrol vapours; etc.); a leak of natural gas; etc.
17. Only put the handset of your telephone next to your ear when it is in normal talk mode.
18. The power adapters are intended to be correctly oriented in a vertical or floor mount position. The prongs are not designed to hold the plug in place if it is plugged into a ceiling, under-the-table or cabinet outlet.
19. Use only the power cord and batteries indicated in this manual. Do not dispose of batteries in a fire. They may explode. Check with local codes for possible special disposal instructions.
20. In wall mounting position, make sure to mount the telephone base on the wall by aligning the eyelets with the mounting studs of the wall plate. Then slide the telephone base down on both mounting studs until it locks into place. Refer to the full instructions in Installation in the user's manual.
21. This product should be mounted at a height of less than 2 meters.
22. Listed PoE (The product is considered not likely to require connection to an Ethernet network with outside plant routing).

   CAUTIONS

- Keep small metallic objects such as pins and staples away from the handset receiver;
- Risk of explosion if battery is replaced by incorrect type;
- Dispose of used batteries according to the instructions;
- Disconnect the telephone line before replacing batteries;
- For pluggable equipment, the socket-outlet (power adaptor) shall be installed near the equipment and shall be easily accessible;
- Avoid using the battery in the following conditions:-
- High or low extreme temperatures that a battery can be subjected to during use, storage or transportation;
- Low air pressure at high altitude;
- Replacement of a battery with an incorrect type that can defeat a safeguard;
- Disposal of a battery into fire or a hot oven, or mechanically crushing or cutting of a battery that can result in an explosion;
- Leaving a battery in an extremely high temperature surrounding environment that can result in an explosion or the leakage of flammable liquid or gas;
- Extremely low air pressure that can result in an explosion or the leakage of flammable liquid or gas.

SAVE THESE INSTRUCTIONS

TABLE OF CONTENTS

Important safety instructions.....2

Parts check list5

Telephone layout7

SIP Contemporary Cordless 1-line - CTM-S2411-X	7
SIP Contemporary Cordless 1-line Accessory Handset - CTM-C4401-X.....	8
Cordless charging stand - C4011-X-USB	9

Installation..... 9

SIP Contemporary Cordless 1-line - CTM-S2411-X	9
Cordless charging stand - C4011-X-USB	12
SIP Contemporary Cordless 1-line Accessory Handset - CTM-C4401-X.....	12

Set up15

SIP Contemporary Cordless 1-line - CTM-S2411-X	15
SIP Contemporary Cordless 1-line Accessory Handset - CTM-C4401-X.....	15
Voice Menu	16

Operation.....17

SIP Contemporary Cordless 1-line - CTM-S2411-X	17
SIP Contemporary Cordless 1-line Accessory Handset - CTM-C4401-X.....	17

Appendix..... 20

Troubleshooting	20
VTech Hospitality Limited Warranty Program	27
Maintenance.....	29
Disclaimer and Limitation of Liability.....	29

European Directives.....	29
--------------------------	----

Declaration of Conformity.....	29
--------------------------------	----



Disposal of batteries and product	30
---	----

Technical specifications31

SIP Contemporary Cordless 1-line - CTM-S2411-X	31
SIP Contemporary Cordless 1-line Accessory Handset - CTM-C4401-X.....	31
Cordless charging stand - C4011-X-USB	31

Parts check list

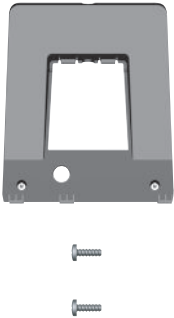
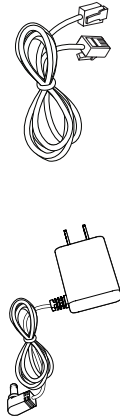
Items contained in the respective **cordless telephone** package:

MODEL NAME	MODEL NUMBER	PARTS INCLUDED				
		TELEPHONE BASE WITH FACEPLATE AND OVERLAY	BASE STAND WALL MOUNT BRACKET	NETWORK CABLE TELEPHONE BASE POWER ADAPTER	CORDLESS HANDSET AND HANDSET BATTERY	HANDSET CHARGING STAND POWER ADAPTER
SIP Contemporary Cordless 1-line Hotel Phone	CTM-S2411-X					
SIP Contemporary Cordless 1-line Accessory Handset	CTM-C4401-X					

Parts check list (continued)

Items contained in the respective **cordless telephone** package:

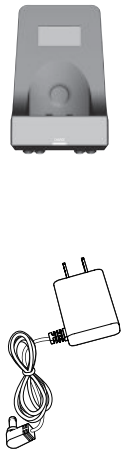
MODEL NAME	MODEL NUMBER	PARTS INCLUDED				
		TELEPHONE BASE WITH FACEPLATE AND OVERLAY	BASE STAND WALL MOUNT BRACKET	NETWORK CABLE TELEPHONE BASE POWER ADAPTER	CORDLESS HANDSET AND HANDSET BATTERY	HANDSET CHARGING STAND POWER ADAPTER
Cordless charging stand	C4011-X-USB					

Telephone layout

SIP Contemporary Cordless 1-line - CTM-S2411-X

SIP Contemporary Cordless 1-line Accessory Handset - CTM-C4401-X

TELEPHONE BASE

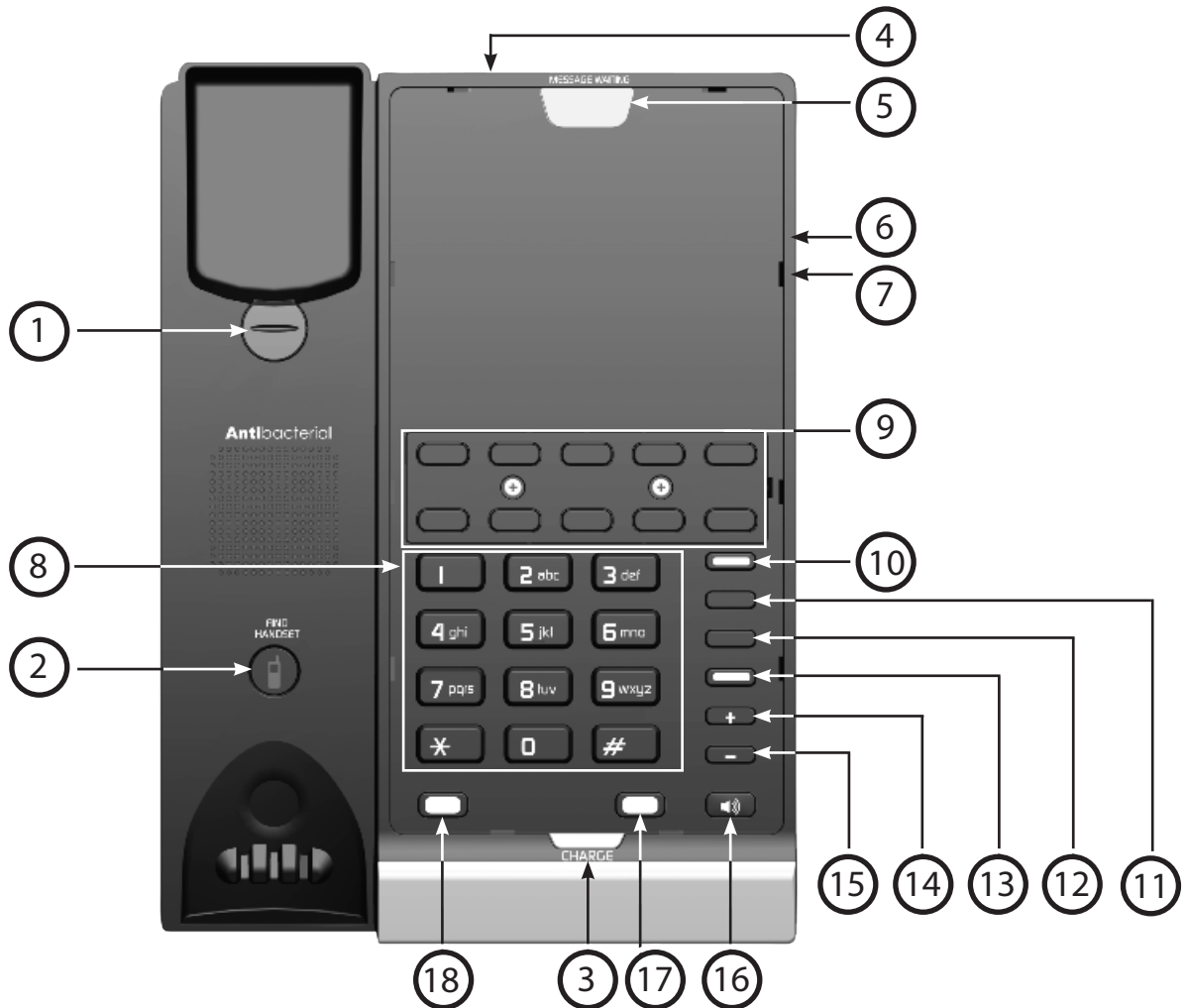

1	Wall mount clip
2	Find Handset button
3	CHARGE LED
4	RJ-45 LAN port
5	Message waiting LED
6	RJ-45 COMPUTER port
7	USB CHARGE ONLY (USB port for charging only)

8	Numeric dial keys
9	Speed dial keys
10	Speed Dial key
11	REDIAL key
12	FLASH key
13	MUTE key
14	VOLUME + ke
15	VOLUME - key
16	SPEAKER key
17	HOLD key
18	LINE key

Telephone layout

SIP Contemporary Cordless 1-line - CTM-S2411-X

SIP Contemporary Cordless 1-line Accessory Handset - CTM-C4401-X

HANDSET

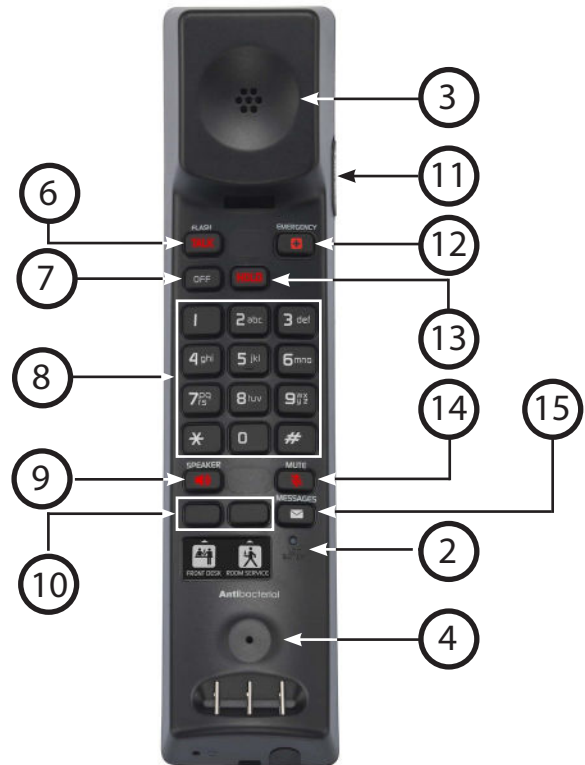
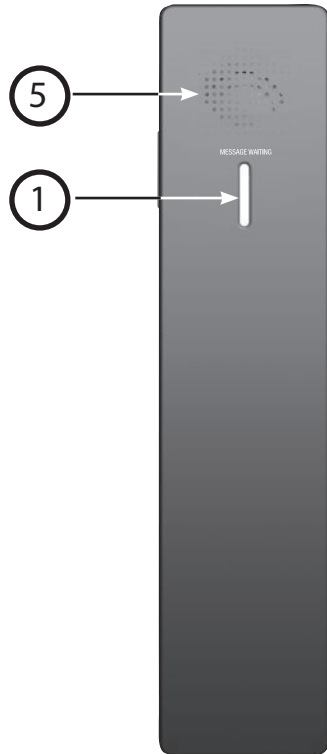

1	Message waiting LED
2	Low battery LED
3	Handset earpiece
4	Microphone
5	Speakerphone

6	TALK/FLASH key
7	OFF/Cancel key
8	Numeric dial keys
9	SPEAKER key
10	Speed dial keys
11	VOLUME +/- keys
12	EMERGENCY key
13	HOLD key
14	MUTE key
15	MESSAGES key

Cordless charging stand - C4011-X-USB-X

Installation

SIP Contemporary Cordless 1-line
CTM-S2411-X

SIP Contemporary Cordless 1-line
Accessory Handset - CTM-C4401-X

INSTALLATION OPTION - INSTALL BASE
STAND FOR DESKTOP

TO MOUNT THE TELEPHONE BASE ON THE BASE
STAND

1. Turn the telephone base over with the bottom side facing up.
2. Insert the lower tabs of the mounting bracket into the lower grooves of the telephone base.
3. Press the upper tabs of the mounting bracket and then push into the center of the telephone base until it locks into place.

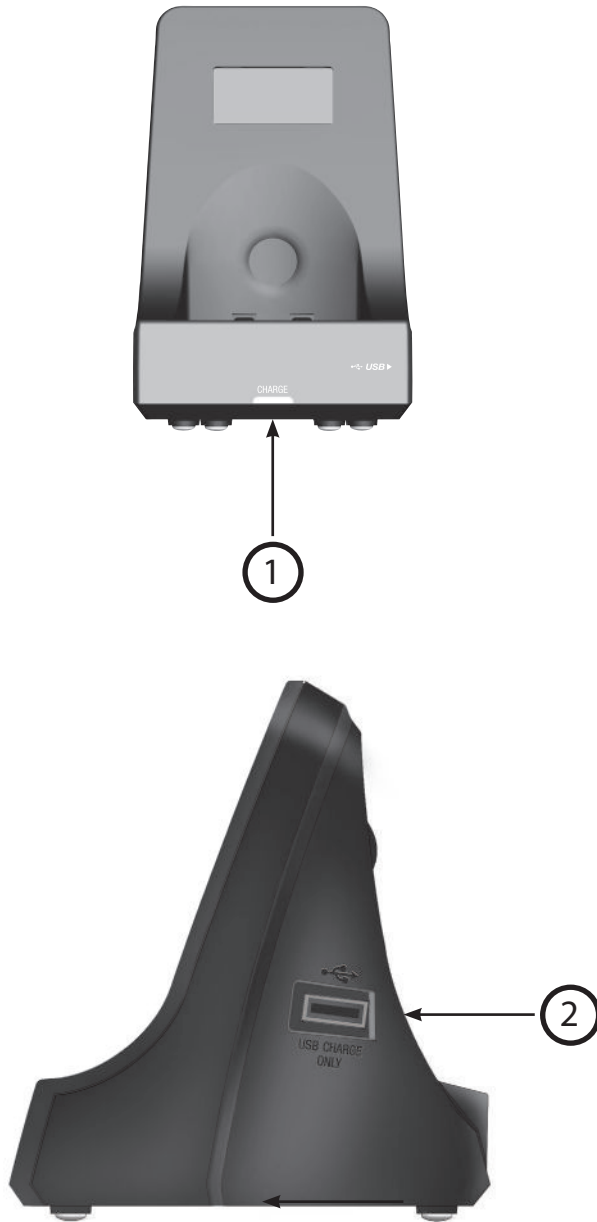

1	Charge LED
2	USB charging port (For charging only)

NOTE

- The USB charging port on the side of the stand is used for charging devices (up to 1A @ 5.1V).



TELEPHONE BASE INSTALLATION

The telephone comes ready for desktop use.

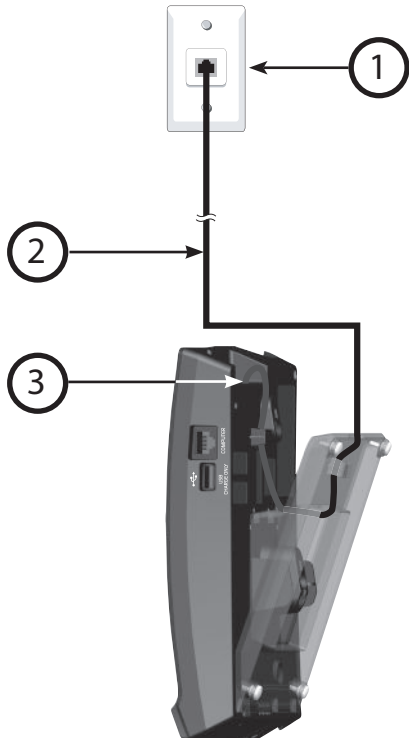
1. Install the telephone base as shown below.
 - Plug the Cat-5 network cable into the RJ-45 LAN port on the telephone base and the network wall jack with Power over Ethernet (PoE).
 - NOTE: Power adapter is not required for Power over Ethernet (PoE).







1	Network wall jack with Power over Ethernet (PoE)
2	Cat-5 network cable
3	RJ-45 LAN port

MUTE /  and  illuminate for 500ms when initialization and system registration are successful.

If the system registration fails, the  key blinks twice every second. To reset, disconnect the Cat-5 network cable from the network wall jack with Power over Ethernet (PoE) and then reconnect.

⚠ CAUTION:

Use only the supplied network cable. The supplied network cable is not designed for use in any other IT devices. Misusing it on your other IT devices shall be prohibited. To order a replacement, call +44 (0)1706 694 070 or email ukca@trustdistribution.com.

2. Once installed, the telephone begins a four-step initialization and system registration process.
 - (1) The **MUTE** /  key and the  key turn on and then go off.
 - (2) The **MUTE** /  key flashes.
 - (3) The **MUTE** /  key stops flashing and then the  key flashes.
 - (4) The **MESSAGE WAITING LED, LINE,**

INSTALLATION OPTION - CONVERTING FROM DESKTOP TO WALL MOUNT POSITION

TO MOUNT THE TELEPHONE BASE ON THE WALL

1. Unplug the Cat-5 network cable from the network wall jack.
2. Remove the cordless handset from the telephone base if it is cradled in the telephone base. On the telephone base, place a coin in the slit of the wall mount clip and rotate a half turn (180 degrees). It locks into place with the protruding edge pointing towards the upper edge of the telephone base. This protruding edge holds the handset when the phone is mounted on the wall.

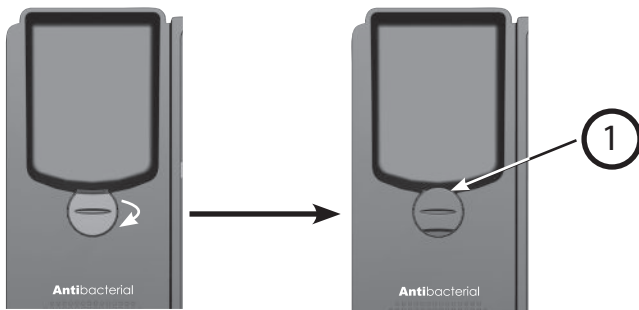

1 | Protruding edge

3. Turn the telephone base over with the bottom side facing up. To remove the mounting bracket, firmly press down the tabs on the mounting bracket and pull them out from the grooves on the telephone base.

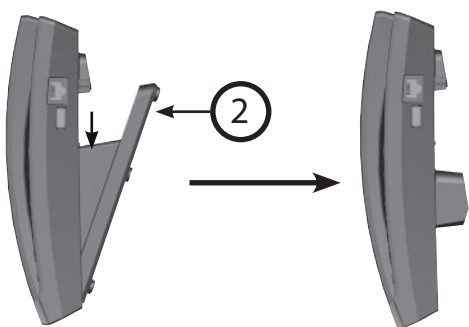

2 | Mounting bracket

4. Mount the telephone base on the wall by aligning the eyelets with the mounting studs of the wall plate. Then slide the telephone base down on both mounting studs until it locks into place.

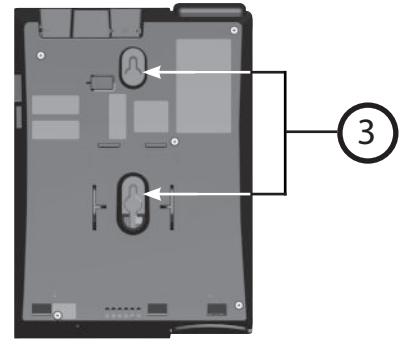

3 | Eyelets

5. Plug the Cat-5 network cable back into the network wall jack with Power over Ethernet (PoE). Then replace the cordless handset on the telephone base cradle.

Installation

Cordless charging stand - C4011-X-USB

INSTALL CHARGING STAND FOR DESKTOP

The charging stand is designed for desktop use. Install the charging stand as shown below.

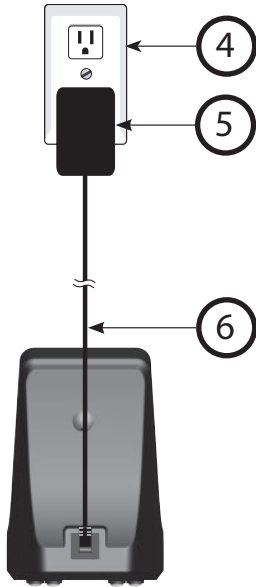

4	Electrical outlet not controlled by a wall switch
5	Power adapter
6	Power cord

⚠ CAUTIONS

Use only the supplied power adapter. The supplied power adapter is not designed for use in any other IT devices. Misusing it on your other IT devices shall be prohibited. To order a replacement, call +44 (0)1706 694 070 or email ukca@trustdistribution.com.

Installation

SIP Contemporary Cordless 1-line Accessory Handset - CTM-C4401-X Handset battery installation

To install the handset battery, follow the steps below.

1. Plug the battery connector securely into the socket inside the handset battery compartment.
2. Place the battery with the label **THIS SIDE UP** facing up and the wires inside the battery compartment.
3. To replace the handset cover, align all the tabs on the handset cover against the corresponding grooves on the handset, then firmly push downward until all the tabs lock in the grooves. Then install the screws at both ends of the handset.

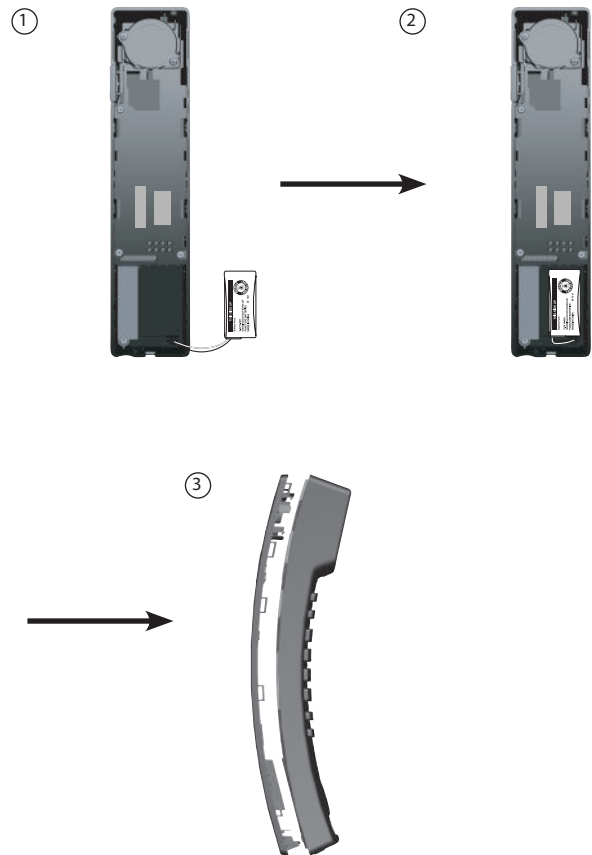

Replace a handset battery

1. Use a 5 mm standard screwdriver to open the screw cover and remove the screw.
2. Insert the screwdriver in the provided slot and then twist and lift to open the bottom part.

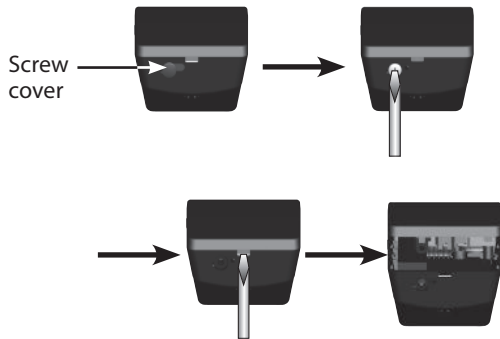

-OR-

Open the bottom part manually at the recessed area to avoid scratching the plastic.



3. Use your thumb to slide along the sides of the handset carefully to release the tabs on the handset cover from the slots on the sides of the handset. Then gently detach the handset cover from the handset.

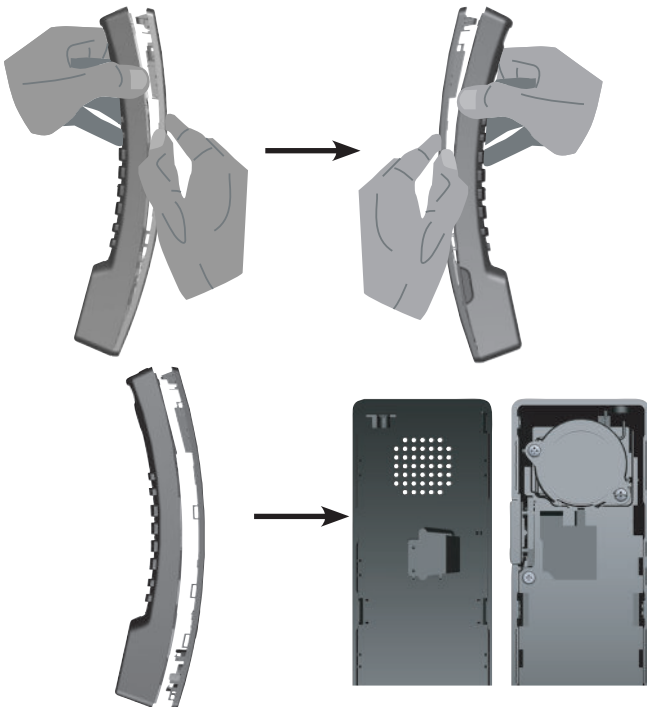

4. Unplug the battery connector from the socket and then remove the battery from the handset battery compartment.
5. Follow Step 2 to Step 4 in Handset battery installation above to install a new battery.

⚠ CAUTIONS

- There may be a risk of explosion if a wrong type of handset battery is used. Use only the supplied rechargeable battery (BT264392/BT266342) or replacement battery (BT266342). To order a replacement, call +44 (0)1706 694 070 or email ukca@trustdistribution.com.
- Dispose of used batteries according to the information in Product disposal instructions on page 29.

HANDSET REGISTRATION

Place the cordless handset on the telephone base cradle. Handset registration happens automatically the first time a cordless handset is placed on the telephone base.

When the registration process completes, the **MESSAGE WAITING** LED flashes once and you hear 3 rising beeps as confirmation.

Each telephone base accommodates up to five cordless handsets. When you already have five registered handsets, you can replace one of them by a new handset if any one of the five registered handsets is disconnected from the base. For example, it is out of range, or its battery is removed or depleted. The previous registered handset is then deregistered from the telephone base.

REGISTER A HANDSET TO ANOTHER TELEPHONE BASE

Any contemporary cordless 1-line handset can register to any contemporary cordless 1-line telephone base.

When a registered cordless handset is idle, place it on another telephone base. This cordless handset automatically registers to the new telephone base.

HANDSET BATTERY CHARGING

The battery must be fully charged before using the cordless handset for the first time. The **CHARGE** LED turns on when the cordless handset is charging on the telephone base. The battery is fully charged after 16 hours of continuous charging. For best performance, keep the cordless handset in the telephone base or charging stand when not in use.

Set up

SIP Contemporary Cordless 1-line - CTM-S2411-X

SIP Contemporary Cordless 1-line Accessory Handset - CTM-C4401-X

Default settings are indicated by asterisks (*).

SETTING	OPTIONS	ADJUSTABLE BY
Listening volume- Handset	1, 2, 3, 4*, 5, 6	User and administrator
Speakerphone volume - Handset	1, 2, 3, 4*, 5, 6	User and administrator
Speakerphone volume - telephone base	1, 2, 3, 4, 5*, 6, 7, 8, 9	User and administrator
Ringer volume - telephone base	1, 2, 3, 4, 5*, 6, 7, 8, 9	User and administrator
Ringer tone	Tone 1*, Tone 2, Tone 3	Administrator only

All telephone settings are programmed through the administrative web portal. Please refer to the SIP Phone Configuration Guide for details.

Voice Menu

The Voice menu enables you to use the handset to query and change phone settings.

To access the Voice Menu:

1. When the phone is idle, press this key sequence on the handset: **TALK * * * ***. A digitized voice on the handset will announce Voice Menu options.
2. Press the number key on the handset to select the desired menu option, or enter information. A list of menu options is shown in the diagram below.

For example, to find out the IP address of the phone, press **1** for Network Configuration, then press **2** for IP Address.

3. When you are finished with the Voice menu, press **OFF** on the handset or place it in the cradle.

NOTE: if you changed any network settings, your phone will automatically reboot. This will enable your new settings to take effect.

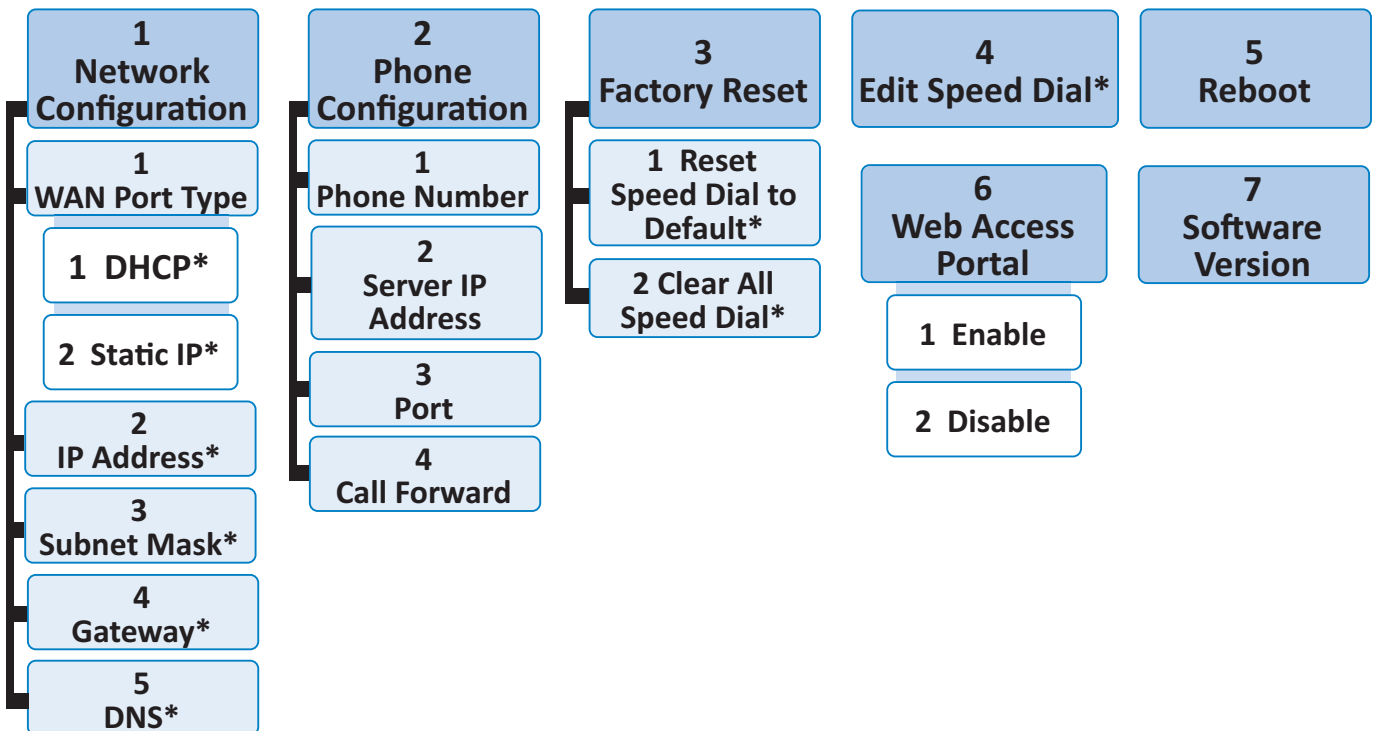

* requires password
(default 1234)

Operation

SIP Contemporary Cordless 1-line-CTM-S2411-X

SIP Contemporary Cordless 1-line Accessory Handset - CTM-C4401-X

USING THE CORDLESS HANDSET AND THE TELEPHONE BASE

The cordless handset and the telephone base speakerphone cannot be used at the same time on a call. However, calls can be switched between the cordless handset and the telephone base speakerphone.

When the cordless handset or the telephone base is in use, the **TALK** key on the cordless handset and the **LINE** key on the telephone base illuminate.

RECEIVE A CALL

When there is an incoming call, the telephone rings. The **LINE** key and the **MESSAGE WAITING** LED on the telephone base flash, and the **TALK** key on the cordless handset flashes.

ANSWER A CALL USING THE CORDLESS HANDSET WHILE IT IS NOT ON THE TELEPHONE BASE OR CHARGING STAND

On the cordless handset, press **TALK** key or .

- The **TALK** key illuminates when in use. The  key illuminates when in speakerphone mode.

ANSWER A CALL USING THE CORDLESS HANDSET WHILE IT IS CRADLED ON THE TELEPHONE BASE OR CHARGING STAND

Lift the cordless handset from the telephone base or charging stand.

- The **TALK** key illuminates when in use. The  key illuminates when in speakerphone mode.

ANSWER A CALL USING THE TELEPHONE BASE

On the telephone base, press **LINE** key or .

- The **LINE** key illuminates when in use. The  key illuminates when in speakerphone mode.

PLACE A CALL

PLACE A CALL USING THE CORDLESS HANDSET

On the cordless handset, press **TALK** key or . Listen for a dial tone and then dial the desired number, or press a Speed Dial key on the cordless handset to dial a programmed number.

- The **TALK** key illuminates when in use. The  key illuminates when in speakerphone mode.

PLACE A CALL USING THE TELEPHONE BASE

On the telephone base, press **LINE** key . Listen for a dial tone and then dial the desired number, or press a Speed Dial key on the telephone base to dial a programmed number.

- The **LINE** key illuminates when in use. The  key illuminates when in use.

END A CALL

END A CALL WHEN USING THE CORDLESS HANDSET

Press **OFF** on the cordless handset or place it in the telephone base or charging stand. The call ends when all handsets hang up.

END A CALL WHEN USING THE TELEPHONE BASE

Press **LINE** key or .

SWITCH A CALL BETWEEN THE CORDLESS HANDSET AND THE TELEPHONE BASE SPEAKERPHONE



- To switch a call from the cordless handset to the telephone base speakerphone, press  on the telephone base.

- To switch a call from the telephone base speakerphone to the cordless handset which is not on the telephone base cradle, press **TALK** or  on the cordless handset.
- To switch a call from the telephone base speakerphone to the cordless handset which is cradled on the telephone base, lift the cordless handset from the telephone base.

JOIN A CALL

During a call, press **TALK** or  on another cordless handset to join.

HANDSET SPEAKERPHONE

During a call, press  on the cordless handset to switch between speakerphone mode and handset earpiece mode. The  key illuminates when in speakerphone mode.

REDIAL

The last dialed number on the telephone base is stored for 15 minutes.

REDIAL THE LAST DIALED NUMBER FROM THE TELEPHONE BASE

Press **LINE** or  to listen for a dial tone. Then press **REDIAL**.

VOLUME

Listening volume can be adjusted on the cordless handset and the telephone base.

ADJUST THE LISTENING VOLUME

- During a call on the handset, press **-/VOLUME/+** to adjust the listening volume. The next call returns to the default listening volume.
- During a call on the telephone base, press **VOLUME+** or **VOLUME-** to adjust the listening volume. The next call returns to the default listening volume.

ADJUST THE RINGER VOLUME OF THE TELEPHONE BASE

Ringer volume of the telephone base can be adjusted.





When the telephone base is idle, press **VOLUME+** or **VOLUME-** to adjust the ringer volume.

CALL WAITING

1. When you hear a call waiting tone during a call, press **FLASH** key on the telephone base or **TALK/FLASH** key on the cordless handset to put the current call on hold and take the new incoming call.
2. Press **TALK** on telephone base or **TALK/FLASH** on cordless handset at any time to switch back and forth between calls.

MUTE

MUTE THE MICROPHONE

1. During a call, press **MUTE** /  .
 - The **MUTE** /  key on the handset / telephone base illuminates when the mute function is turned on. You can hear the party on the other end, but they cannot hear you.
2. Press **MUTE** /  again to resume the conversation.
 - The light on the  key turns off.

MESSAGE WAITING INDICATOR

When a voice message is received, the message waiting LEDs on the telephone base and the cordless handset flashes.

PLAY MESSAGES

Press **MESSAGES** on the cordless handset in idle mode to play messages.



HOLD

TO PLACE A CALL ON HOLD:

1. During a call, press the **HOLD** key on the telephone base or the cordless handset.

- The **TALK** key on the cordless handset and the **LINE** key on the telephone base flash when the call is on hold.

TO TAKE THE CALL OFF HOLD:

1. Press **TALK** or  on the handset, OR press **LINE** or  on the telephone base or the call will end automatically after the preset call on hold duration.
 - The **TALK** key illuminates when in use. The  key illuminates when in speakerphone mode.

ANSWER A CALL USING THE TELEPHONE BASE

On the telephone base, press .

- The  key illuminates when in use.

FIND HANDSET

Use this feature to find all registered cordless handsets.

TO START PAGING:

Press /FIND HANDSET on the telephone base when the phone is not in use. All idle cordless handsets beep for 60 seconds.

TO END PAGING:

- Press /FIND HANDSET again on the telephone base.

-OR-

- Press any key on the cordless handset to stop the paging tone.

COMPUTER PORT

You can route your computer through the COMPUTER port (RJ-45) on the side of the telephone base to get Internet access.

USB PORT

The  port on the side of the telephone base can be used for charging devices (up to 500mA @ 5V). Charging will be suspended when there is an incoming call or the telephone is in use.

Appendix

Troubleshooting

If you have difficulty with the telephones, please try the suggestions below. For customer service, call +44 (0)1706 694 070 or email ukca@trustdistribution.com.

FOR CORDLESS TELEPHONE

QUESTION	SUGGESTIONS
The telephone does not work at all.	<ul style="list-style-type: none">• Make sure the Cat-5 network cable is plugged into the LAN port of the telephone base and the network wall jack with Power over Ethernet (PoE).• Make sure the battery is installed and charged correctly (pages 12-13). For optimum daily performance, return the cordless handset to the telephone base or charging stand after use.• Unplug the Cat-5 network cable from the network wall jack. Wait for approximately 15 seconds, then plug it back in.• Charge the battery in the cordless handset for up to 16 hours.• If the battery is completely depleted, charge the battery for at least 30 minutes before use.• Remove the battery and then install it again. If that still does not work, it may be necessary to purchase a new battery.• Disconnect the telephone base from the network wall jack and connect a different working SIP telephone. If the other SIP telephone does not work, the problem is probably in the wiring or network server. Check your SIP server settings. Refer to the SIP Phone Configuration Guide for details.

QUESTION

SUGGESTIONS

There is no dial tone.

- Try all the above suggestions.
- The Cat-5 network cable may be defective. Install a new Cat-5 network cable.
- Make sure your network is providing Power over Ethernet (PoE).
- Disconnect the telephone base from the network wall jack and connect a different working SIP telephone. If there is no dial tone on this telephone either, the problem is in your wiring or network server. Check your SIP server settings and refer to the **SIP Phone Configuration Guide** for details.
- Make sure the initialization and system registration process completes (pages 10 and 14). The speakerphone key blinks twice every second if there are errors with the initialization and system registration process. Check your SIP server settings. Refer to the **SIP Phone Configuration Guide** for details.

I cannot dial out.

- Try all the above suggestions.
- Make sure there is a dial tone before dialling. It is normal if the cordless handset takes a second or two to synchronise with the telephone base before producing a dial tone. Wait an extra second before dialling.
- A prefix may be required for dialling some internal or external calls. Refer to the **SIP Phone Configuration Guide** for details.
- Check your SIP server settings. If other SIP telephones in your hotel are having the same problem, the problem is in the wiring or network server. Contact your telephone service provider (charges may apply).

QUESTION**SUGGESTIONS**

The Speed Dial key does not work at all.

- The Speed Dial key may not be properly programmed. Refer to the **SIP Phone Configuration Guide** for details.

The telephone cannot register to the SIP network server.

- Make sure your network is providing Power over Ethernet (PoE).
- Make sure the initialization and system registration process completes (pages 9 and 14).
- If there is an error during the initialization and system registration process, the  key flashes twice every second. Disconnect the Cat-5 network cable from the network wall jack and connect it back into the network wall jack with Power over Ethernet (PoE) to start the initialization and system registration process again.

The LOW BATTERY LED illuminates on the cordless handset.

- Place the cordless handset in the telephone base or charging stand for recharging.
 - Remove the battery and then install it again, and use it until fully depleted. Then charge the cordless handset in the telephone base or charging stand for up to 16 hours.
 - If the above measures do not correct the problem, replace the battery.
-

QUESTION

The battery does not charge in the cordless handset or the battery does not accept charge.

SUGGESTIONS

- Make sure the cordless handset is placed in the telephone base or charging stand correctly. The **CHARGE** LED should be on.
- Remove the battery and then install it again. Charge it for up to 16 hours.
- If the cordless handset is placed in the telephone base or charging stand but the **CHARGE** LED is not on, refer to **The CHARGE LED is off** below.
- If the battery is completely depleted, charge the cordless handset for at least 30 minutes before use.
- If the above measures do not correct the problem, replace the battery.

The **CHARGE** LED is off

- Clean the charging contacts on the cordless handset, telephone base, and/or charging stand each month with a pencil eraser or a dry non-abrasive fabric.
 - Make sure the Cat-5 network cable is plugged in correctly and securely.
 - Unplug the Cat-5 network cable. Wait for 15 seconds before plugging it back in.
-

The telephone does not ring when there is an incoming call.

- Make sure the Cat-5 network cable is plugged into the **LAN** port of the telephone base and the network wall jack with Power over Ethernet (PoE).
 - The cordless handset may be too far from the telephone base. Move it closer to the telephone base.
 - Check your SIP server or telephone administrative settings. Refer to the **SIP Phone Configuration Guide** for details.
 - If other SIP telephones in your hotel are having the same problem, the problem is in the wiring or network server. Contact your telephone service provider (charges may apply).
 - Other electronic products such as HAM radios and other DECT phones can cause interference with your cordless phone. Try installing your phone as far away as possible from these types of electronic devices.
 - The Cat-5 network cable may be defective. Install a new Cat-5 network cable.
 - Remove the battery and then install it again. Then place the cordless handset in the telephone base. Wait for the handset to synchronise with the telephone base. Allow up to one minute for this to take place.
-

The cordless handset beeps and is not performing normally.

- Make sure the Cat-5 network cable is plugged into the **LAN** port of the telephone base and the network wall jack with Power over Ethernet (PoE).
- Check your SIP server or telephone administrative settings. Refer to the **SIP Phone Configuration Guide** for details.
- Disconnect the telephone base from the network wall jack and connect a different working SIP telephone. If the other SIP telephone has the same problem, the problem is in the wiring or network server. Contact your telephone service provider (charges may apply).
- Other electronic products such as HAM radios and other DECT phones can cause interference with your cordless phone. Try installing your phone as far away as possible from these types of electronic devices.

There is interference during a telephone conversation, or the call fades in and out when I am using the cordless handset.

- The cordless handset may be out of range. Move the handset closer to the telephone base or adjust the setting of RF transmission power. Refer **SIP Phone Configuration Guide** for details.
- Other electronic products such as HAM radios and other DECT phones can cause interference with your cordless phone. Try installing your phone as far away as possible from these types of electronic devices.
- If other SIP telephones in your hotel are having the same problem, the problem is in the wiring or network server. Contact your telephone service provider (charges may apply).

QUESTION	SUGGESTIONS
<p>I hear other calls when using the telephone.</p>	<ul style="list-style-type: none"> • Disconnect the telephone base from the network wall jack and connect a different working SIP telephone. Check your SIP server settings. If calls are still not clear, the problem is probably in the wiring or network server. Contact your telephone service provider (charges may apply).
<p>I hear noise on the cordless handset and the keys do not work.</p>	<ul style="list-style-type: none"> • Make sure the Cat-5 network cable is plugged in correctly and securely. • Unplug the Cat-5 network cable. Wait for 15 seconds before plugging it back in.
<p>Common cure for electronic equipment.</p>	<ul style="list-style-type: none"> • If the telephone is not responding normally, put the cordless handset in the telephone base. If it does not fix the problem, try the following (in the order listed): <ol style="list-style-type: none"> 1. Disconnect the power to the telephone base. 2. Disconnect the battery on the cordless handset. 3. Wait a few minutes before connecting power to the telephone base. 4. Install the battery again and then place the cordless handset in the telephone base. 5. Wait for the cordless handset to synchronise with the telephone base. Allow up to one minute for this to take place.

Appendix

VTech Hospitality Limited Warranty Program

VTech Telecommunications Limited, the manufacturer of VTech Hospitality Product ("Product"), warrants to the holder of a valid proof of purchase ("end user" or "you") that the Product and all accessories provided by VTech in the Product's package are free from defects in material and workmanship, pursuant to the following terms and conditions, when installed and used normally and in accordance with the Product's operating instructions. The limited warranty extends to the end user of this Product and applies only if such Product is purchased through a local distributor /dealer. The limited warranty period for this Product is determined based on the following:

5 YEARS – ANALOG MODELS

- All Classic Models – corded and cordless
- All Contemporary Models – corded and cordless
- All TrimStyle Models

2 YEARS – SIP NON-DISPLAY MODELS

- All Classic Models – corded and cordless
- All Contemporary Models – corded and cordless
- All TrimStyle Models

During the limited warranty period, VTech's authorised service representative will repair or replace, at VTech's option, without charge, a Product that is not free from defects in materials and workmanship. If VTech's authorised service representative repairs the Product, new or refurbished replacement parts may be used. If the Product is replaced, it may be replaced with a new or refurbished Product of the same or similar design. Repair or replacement of Product, at VTech's option, is the exclusive remedy.

The limited warranty period for the Product begins on the date that the end user takes possession of the Product. This limited warranty also applies to repaired or replacement Products for a period of either: (a) 90 days from the date the repaired or replacement Product is shipped to you; or (b) the time remaining on the original limited warranty as described above; whichever is longer.

This limited warranty does not cover:

1. Product or parts that have been subjected to misuse, accident, shipping or other physical damage, improper installation, abnormal operation or handling, neglect, inundation, fire, water or other liquid intrusion; or
2. Product that has been damaged due to repair, alteration or modification by anyone other than an authorised service representative of VTech; or
3. Product to the extent that the problem experienced is caused by signal conditions, network reliability or cable or antenna systems; or
4. Product to the extent that the problem is caused by use with non-VTech accessories; or

5. Product whose warranty/quality stickers, product serial number plates or electronic serial numbers have been removed, altered or rendered illegible; or
6. Product purchased, used, serviced, or shipped for repair from outside the local dealer / distributor, or used for non-approved commercial or institutional purposes (including but not limited to Products used for rental purposes); or
7. Product returned without valid proof of purchase; or
8. Charges or costs incurred by the end user, and risk of loss or damage, in removing and shipping the Product, or for installation or set up, adjustment of customer controls, and installation or repair of systems outside the unit.
9. Line cords or coil cords, plastic overlays, connectors, power adapters and batteries, if the Product is returned without them. VTech will charge the end user at then-current prices for each of the missing items.
10. NiCd or NiMH handset batteries, or power adapters, which, under all circumstances, are covered by a one (1) year warranty only.

Except as provided by applicable law, you assume the risk of loss or damage during transit and transportation and are responsible for delivery or handling charges incurred in the transport of Product(s) to the service location. VTech's authorised service representative will return repaired or replaced product under this limited warranty to you, transportation, delivery and handling charges prepaid. VTech assumes no risk for damage or loss of the Product in transit.

If the Product failure is not covered by this limited warranty, or proof of purchase does not meet the terms of this limited warranty, VTech will notify you and will request that you authorise the cost of repair and return shipping costs for the repair of Products that not covered by this

limited warranty. You must pay for the cost of repair and return shipping costs for the repair of Products that are not covered by this limited warranty.

OTHER LIMITATIONS

This warranty is the complete and exclusive agreement between you and VTech. It supersedes all other written or oral communications related to this Product. VTech provides no other warranties for this Product, whether express or implied, oral or written, or statutory. The warranty exclusively describes all of VTech's responsibilities regarding the Product. No one is authorised to make modifications to this warranty and you should not rely on any such modification.

VTech's liability to end user hereunder shall not exceed the purchase price of the Product. In no event shall VTech be liable for any indirect, special, incidental, consequential, or similar damages (including, but not limited to lost profits or revenue, inability to use the product, or other associated equipment, the cost of substitute equipment, and claims by third parties) resulting from the use of this Product. Some local dealers / distributors do not allow the exclusion or limitation of incidental or consequential damages, so the above limitation or exclusion may not apply to you.

This warranty gives you specific legal rights, and you also have other rights which vary from local dealer / distributor to local dealer / distributor.

Maintenance

TAKING CARE OF YOUR TELEPHONE

Your telephone contains sophisticated electronic parts, so it must be treated with care.

AVOID ROUGH TREATMENT

Place the handset down gently. Save the original packing materials to protect your telephone if you ever need to ship it.

AVOID WATER

Your telephone can be damaged if it gets wet. Do not use the handset outdoors in the rain, or handle it with wet hands. Do not install the telephone base near a sink, bathtub or shower.

ELECTRICAL STORMS

Electrical storms can sometimes cause power surges harmful to electronic equipment. For your own safety, take caution when using electrical appliances during storms.

CLEANING YOUR TELEPHONE

Your telephone has a durable plastic casing that should retain its luster for many years. Clean it only with a soft cloth slightly dampened with water or mild soap. Do not use excess water or cleaning solvents of any kind.

Disclaimer and Limitation of Liability

VTech Telecommunications Limited and its suppliers assume no responsibility for any damage or loss resulting from the use of this user's manual. VTech Telecommunications Limited and its suppliers assume no responsibility for any loss or claims by third parties that may arise through the use of this product. VTech Telecommunications Limited and its suppliers assume no responsibility for any damage or loss caused by deletion of data as a result of malfunction, dead battery, or repairs. Be sure to make backup copies of important data on other media to protect against data loss.

REMEMBER THAT ELECTRICAL APPLIANCES CAN CAUSE SERIOUS INJURY IF USED WHEN YOU ARE WET OR STANDING IN WATER. IF THE TELEPHONE BASE SHOULD FALL INTO WATER, DO NOT RETRIEVE IT UNTIL YOU UNPLUG THE POWER CORD AND/OR TELEPHONE LINE CORD FROM THE WALL. THEN REMOVE THE TELEPHONE BY THE UNPLUGGED CORDS.

European Directives

This equipment is compliant with 2014/53/EU (RED) and 2011/65/EU (ROHS).

Declaration of Conformity

The Declaration of Conformity may be obtained from:
www.vtechhotelphones.com.



Disposal of batteries and product

These symbols (①, ②) on the products, packaging, and/or accompanying documents mean that used electrical and electronic products and batteries must not be mixed with general household waste.

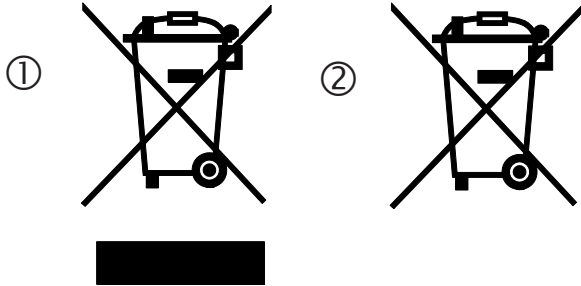

For proper treatment, recovery and recycling of old products and batteries, please take them to applicable collection points in accordance with your national legislation.

By disposing of them correctly, you will help to save valuable resources and prevent any potential negative effects on human health and the environment.

For more information about collection and recycling, please contact your local municipality. Penalties may be applicable for incorrect disposal of this waste, in accordance with national legislation.

PRODUCT DISPOSAL INSTRUCTIONS FOR BUSINESS USERS

If you wish to discard electrical and electronic equipment, please contact your dealer or supplier for further information.

INFORMATION ON DISPOSAL IN OTHER COUNTRIES OUTSIDE THE EUROPEAN UNION

These symbols (①, ②) are only valid in the European Union. If you wish to discard these items, please contact your local authorities or dealer and ask for the correct method of disposal.

NOTE FOR THE BATTERY SYMBOL

This symbol (②) might be used in combination with a chemical symbol. In this case it complies with the requirement set by the Directive for the chemical involved.

Technical specifications

SIP Contemporary Cordless 1-line - CTM-S2411-X

Frequency control	Crystal controlled PLL synthesizer
Transmit frequency	1921.536-1928.448 MHz
Channels	5
Nominal effective range	Maximum power allowed by FCC and IC. Actual operating range may vary according to environmental conditions at the time of use.
Power requirement	T2.4V Ni-MH battery
Message waiting signal	From SIP server
Speed Dial memory	Telephone base: up to 11 memory locations; up to 32 digits
Size	Telephone base: 8.03 x 6.06 x 3.78 in (204 x 154 x 96 mm) Handset: 8.39 x 1.89 x 1.65 in (213 x 48 x 42 mm)

SIP contemporary cordless 1-line accessory handset - CTM-C4401-X

Frequency control	Crystal controlled PLL synthesizer
Transmit frequency	1921.536-1928.448 MHz
Channels	5
Nominal effective range	Maximum power allowed by FCC and IC. Actual operating range may vary according to environmental conditions at the time of use.
Power requirement	2.4V Ni-MH battery
Message waiting signal	From SIP server
Speed Dial memory	Handset: up to 3 memory locations; up to 32 digits
Size	Telephone base: 8.03 x 6.06 x 3.78 in (204 x 154 x 96 mm) Handset: 8.39 x 1.89 x 1.65 in (213 x 48 x 42 mm)

Cordless charging stand - C4011-X-USB

Power requirement	6V DC @450mA
Size	3.78 x 2.80 x 4.29 in (96 x 71 x 109 mm)

Index

A

Answer a call 17

B

Battery 3, 12, 13, 14, 20, 21, 23, 24, 26, 28, 29

Battery charging 14, 20, 22

C

Call waiting 18

E

End a call 17

H

Handset Registration 14

Handset speakerphone 18

Hold 18

I

Important safety instructions 2

Installation 9-14

Base stand 9

Charging stand 12

Handset Battery 12, 13

Telephone Base 9, 10

Wall Mount 11

J

Join a call 18

L

Limited Warranty 27

Listening volume 18

M

Mute 18

P

Place a call 17

R

Receive a call 17

Registration, Handset 14

Ringer tone 15

Ringer volume 18

S

Speakerphone 15, 18

T

Technical specification 31

Troubleshooting 20

V

Voice menu 16

Volume 18

W

Wall mount 11

Warranty 27



Specifications are subject to change without notice.

Copyright © 2022

Vtech Telecommunications Limited

All rights reserved. 01/22.

CTM-S2411-X_CTM-C4401-X_C4011-X-USB_UG_V1_CEC_EU_UK_2022.01.04